

**Susol**  
Super Solution

## Aluminum Case Plug-in Busways

**LS** IS

Susol Aluminum Case Plug-in Busways



# *Susol* Busways



**Challenges to the top-class product by LSIS!**  
*Susol Busways*



**Super Solution**

# Contents :

Features	06
Basic structure	08
Application	10
Rating	11
Cross section and dimensions	12
Grounding structure	13
Busways components	14
Busways standard components	15
Busways Electrical Characteristics	22

# Susol Busways

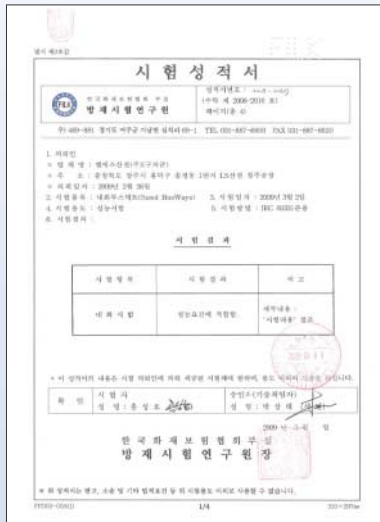

# *Susol*

**Super Solution**



- **Super** Compact size & Light weight
- **Super** Performance & Service
- **Super** Reliability & Safety
- **Super** Easy installation

# Super Solution created by the combination of *Susol Busways* and other LSIS products!

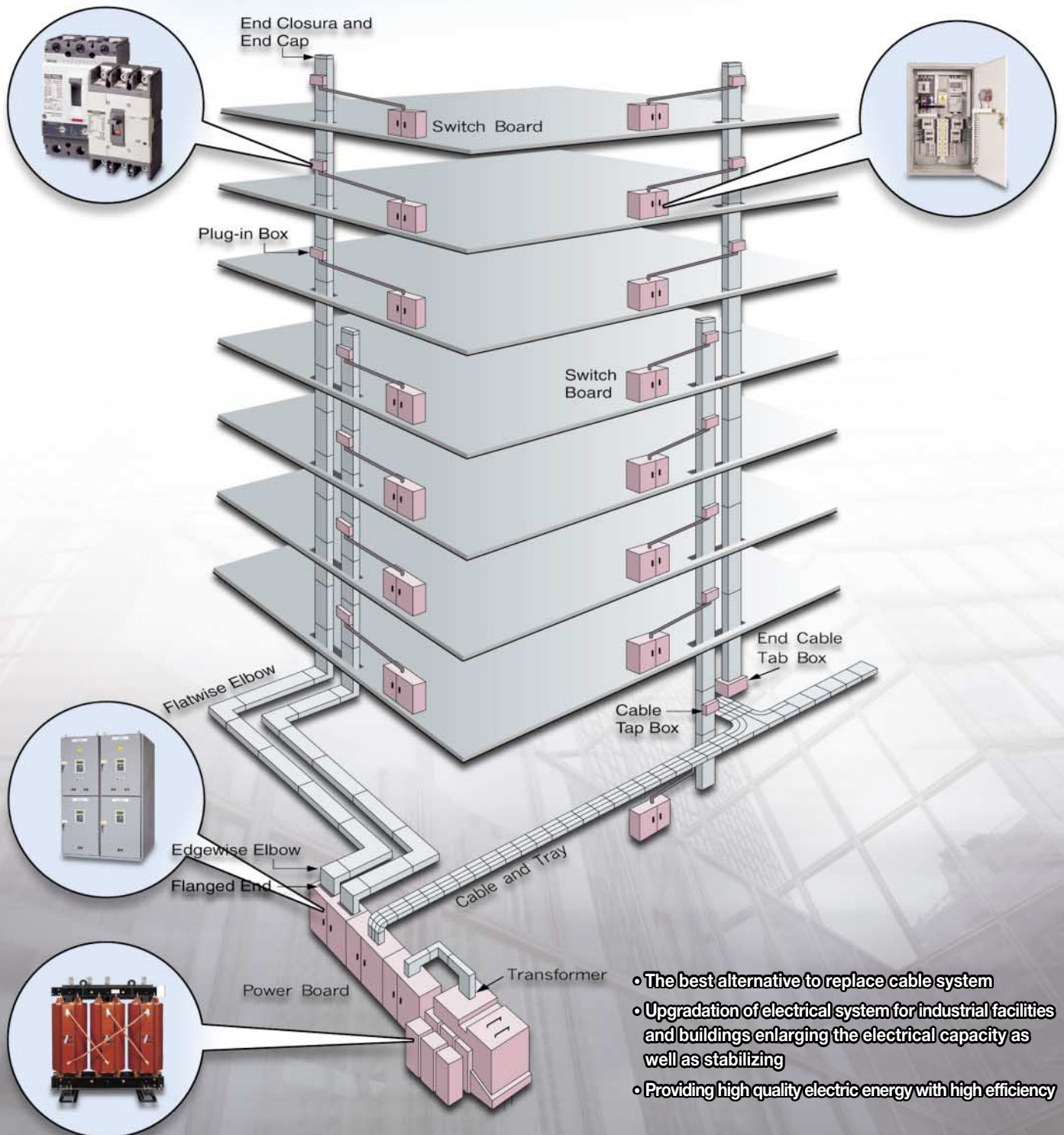

- The best alternative to replace cable system
- Upgradation of electrical system for industrial facilities and buildings enlarging the electrical capacity as well as stabilizing
- Providing high quality electric energy with high efficiency

# Super Features

Realization of the best performance  
over 30 years experience



## Compact Size

- being smaller and lighter than conventional model by 40%

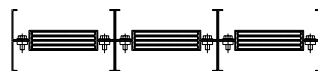

Conventional 4000A(Cu) Model

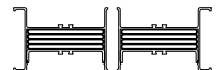

Susol Busways  
4000A(Cu) Model



## Maximum capacity

- Al type upto 6000A
- Cu type upto 7500A



Al Type, 6000A Model

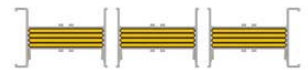

## Insulation

- Breakdown voltage over 30kV/mm
- Batch extrusion coating system applied



## Degree of protection

- IP54 or IP65

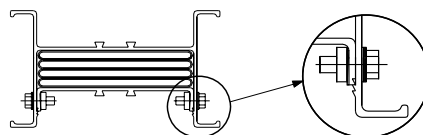

# Future-oriented distribution system

## *Susol Busways*



### High stability and reliability

- High short time current capacity  
Cu type: 2000A(135kA/1sec), 4000A(220kA/1sec)
- High resistance to fire: 840°C/180min
- Lower voltage drop, influence of induction and noise



### Environmental friendliness and light weight

- Adoption of environmentally friendly insulator and high strength Aluminum alloy
- Reduction of the max. weight by 50% thanks to Aluminum case



### Easy construction and maintenance

- Convenience of assembling by special joint pack

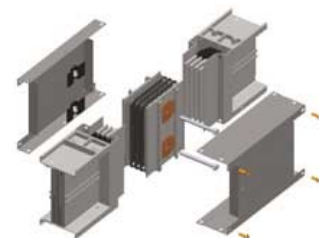

### Options

- Grounding to aluminum case ( over 100% )
- Fault monitoring system

# Susol Busways



## ■ New concept of jointing

New assembling method using special joint pack is applied to all the Susol busways.

This technology enlarges the contact area by using both surface contacting and uses only one torque value( 1000kgf • cm) for all models, which result in more convenient construction and stable jointing.



# Basic structure

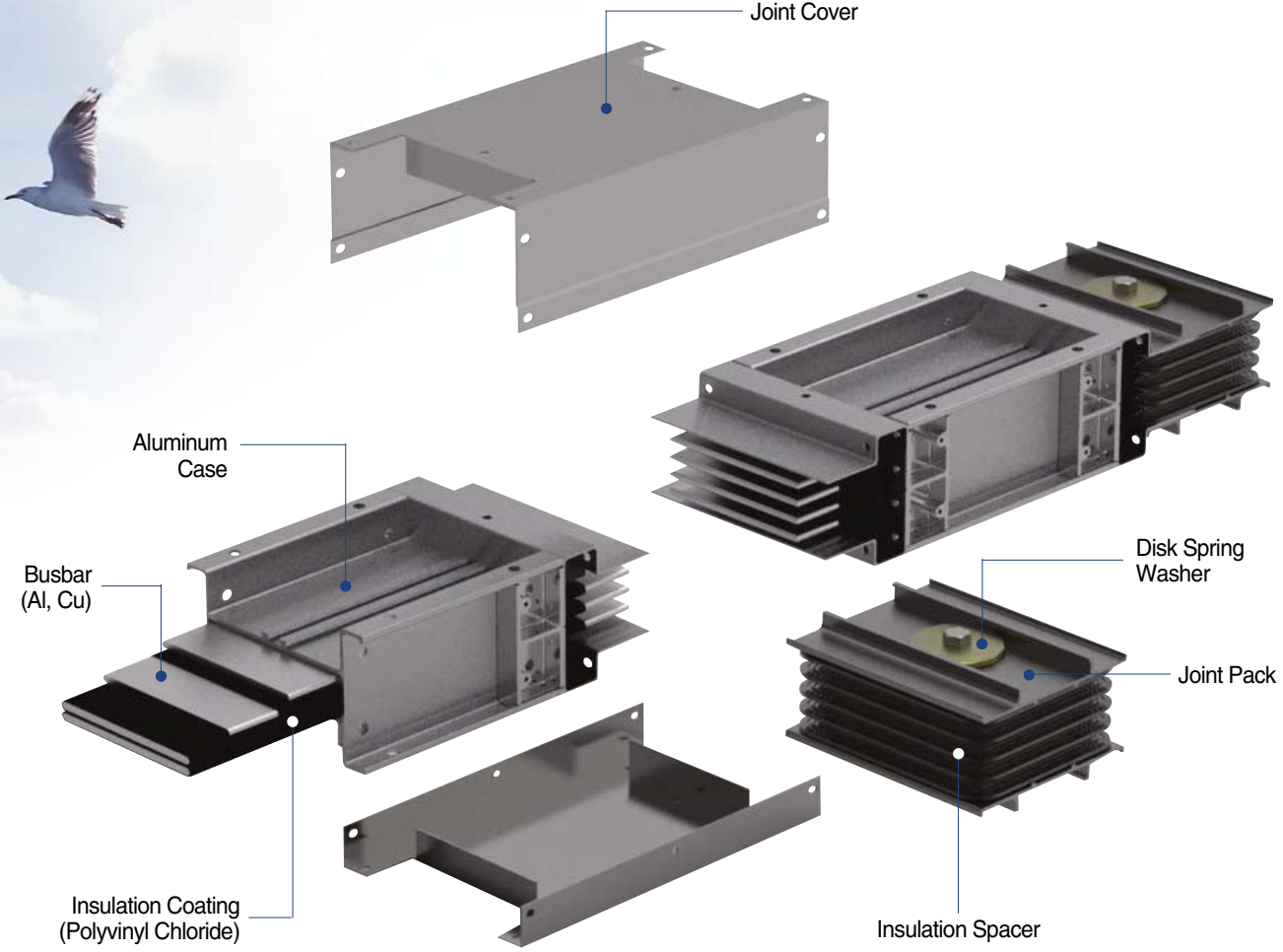

# Application

Susol

## Building distribution system

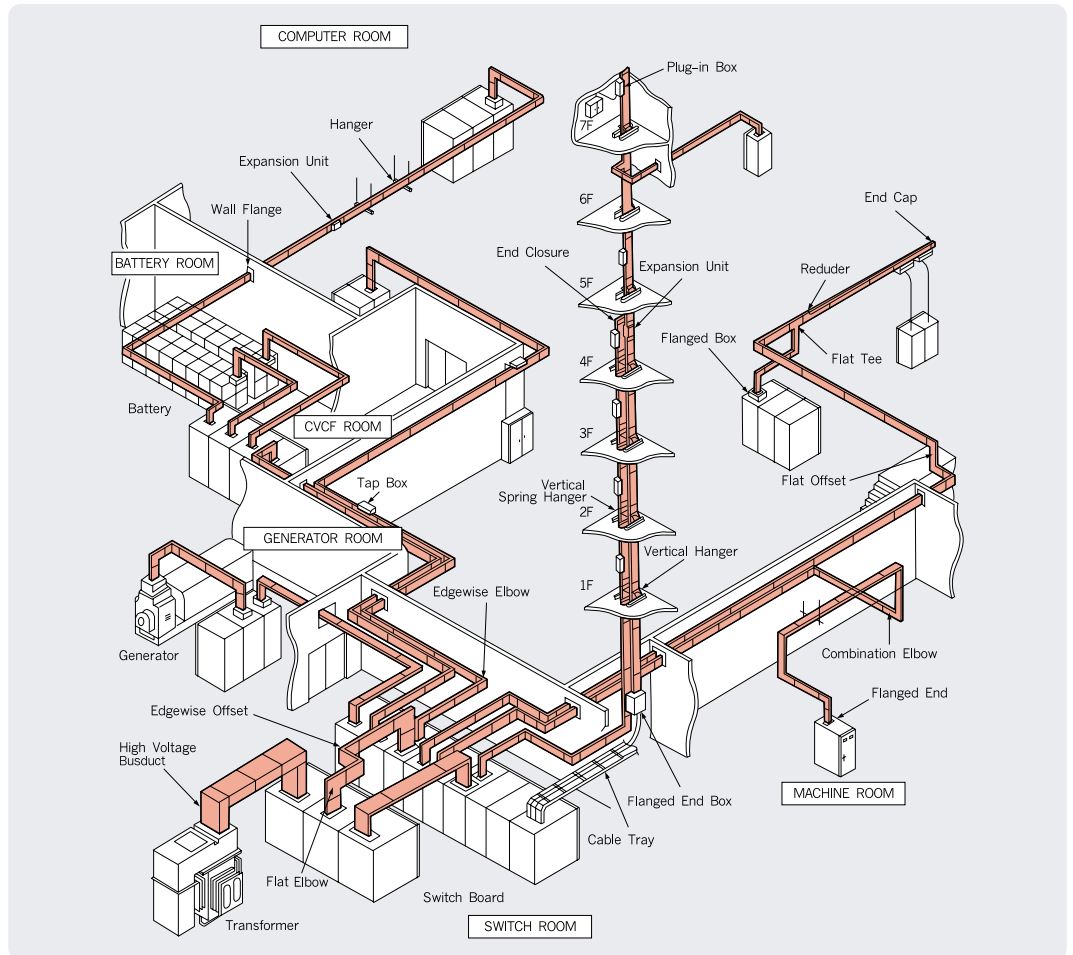

## Plant distribution system

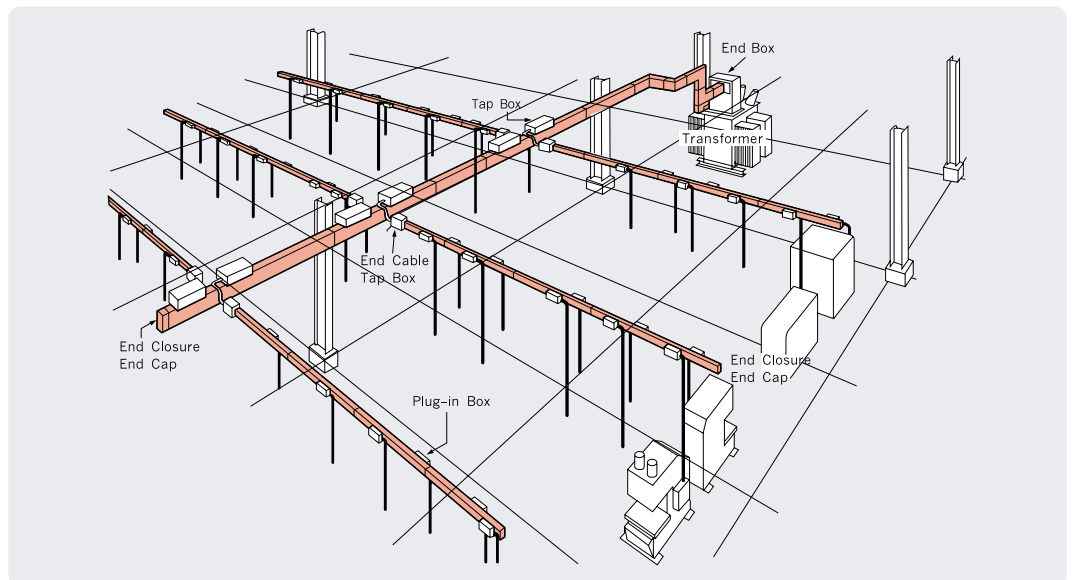

# Rating

**Susol**

Susol Busways are plug-in type insulated main bus system suitable for all power lines in low voltage industrial equipments and buildings.

Item	Rating		
Rated voltage	AC1000V/DC1500V		
Rated current	Al	630 ~ 6000A	
	Cu	630 ~ 7500A	
Rated frequency	50 / 60Hz		
Short-time withstand current	Al	2000A	121kA/1sec
		4000A	200kA/1sec
	Cu	2000A	135kA/1sec
		4000A	220kA/1sec
Wiring system	3W, 4W, 5W		
Grounding	Basic method	grounding to housing	
	Maximum capacity	over 200%	
	Grounding type	housing : over 100% Internal Type : 50/100 %	
Resistance to fire	AC 1000 V : 840°C / 180min.		
Degree of protection	Indoor	IP54	
	Outdoor	IP65	
Enclosure material	High Strength Aluminum Extrusion (Thickness : 3 mm)		
Insulation material	Poly Amide - 66 (thermoplastic)		
Conductor material	Aluminum or Copper		
Environment	Altitude	below 1000m	
	Ambient temp	-25 ~ 40°C	
	Humidity	below 97%	
Allowable temp. (IEC standard)	Housing	55K	
	Joint part	95K	
Color of painting	MUNSELL No.	5Y 7/1	
		7.5 BG 6 / 1.5	
Standard	IEC 60439 - 1, 2		

# Cross section and dimensions

Susol

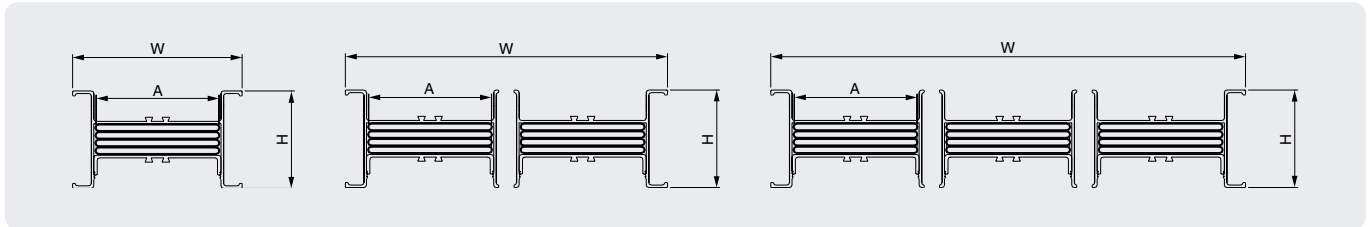

<Fig.1>

<Fig.2>

<Fig.3>

## Al Type

Rated current (A)	Fig.	Al Busbar		3W				4W				5W			
		T (mm)	A (mm)	W (mm)	H (mm)	Weight(kg/m)		W (mm)	H (mm)	Weight(kg/m)		W (mm)	H (mm)	Weight(kg/m)	
						3W	1/2E			4W	1/2E			5W	1/2E
630	Fig.1	6.4	41×1	96	106	6.1	6.4	96	115	6.9	7.2	96	124	7.7	8.1
800			62×1	117		7.7	8.2	117		8.9	9.4	117		10.1	10.6
1000			86×1	141		9.3	10.0	141		10.9	11.6	141		12.5	13.2
1250			108×1	163		10.8	11.6	163		12.8	13.6	163		14.8	15.6
1600			164×1	219		14.6	15.9	219		17.5	18.8	219		20.5	21.7
2000			210×1	265		17.7	19.3	265		21.4	23.1	265		25.1	26.8
2500	Fig.2	6.4	126×2	342	106	23.3	25.2	342	115	27.9	29.8	342	124	32.5	34.4
3200			164×2	418		28.4	31.0	418		34.3	36.9	418		40.2	42.8
3600			184×2	458		31.1	34.0	458		37.7	40.6	458		44.2	47.1
4000			210×2	510		34.7	37.9	510		42.1	45.4	510		49.6	52.8
5000	Fig.3	6.4	184×3	677	106	46.3	50.7	677	115	56.9	60.5	677	124	65.9	70.2
6000			210×3	755		51.6	56.5	755		62.8	67.7	755		74.0	78.9

## Cu Type

Rated current (A)	Fig.	Cu Busbar		3W				4W				5W			
		t (mm)	A (mm)	W (mm)	H (mm)	Weight(kg/m)		W (mm)	H (mm)	Weight(kg/m)		W (mm)	H (mm)	Weight(kg/m)	
						3W	1/2E			4W	1/2E			5W	1/2E
630	Fig.1	6.4	41×1	96	106	10.9	11.9	96	115	13.3	14.2	96	124	15.6	16.7
800			41×1	96		10.9	11.9	96		13.3	14.2	96		15.6	16.7
1000			57×1	112		14.0	15.5	112		17.4	18.7	112		20.7	22.1
1250			73×1	128		17.0	18.9	128		21.3	23.1	128		25.6	27.4
1600			108×1	163		23.5	26.3	163		29.7	32.7	163		36.3	39.1
2000			145×1	200		30.4	34.1	200		38.7	42.9	200		47.6	51.4
2500	Fig.2	6.4	195×1	250	106	39.6	44.7	250	115	50.8	56.5	250	124	62.9	68.0
3200			108×2	306		46.3	51.8	306		59.3	64.8	306		72.0	77.5
3600			126×2	342		52.9	59.5	342		68.2	74.7	342		83.0	89.5
4000			145×2	380		60.0	67.5	380		77.7	85.1	380		94.6	102.1
5000	Fig.3	6.4	195×2	480	106	78.5	88.6	480	115	102.5	112.5	480	124	125.2	135.3
6000			145×3	560		89.6	100.8	560		115.7	126.9	560		141.1	152.3
7500			195×3	710		117.5	132.6	710		152.9	168.0	710		187.0	202.2

# Grounding structure

Susol

- Grounding function over 100% of main capacity by using aluminum extrusion material for case.
- Additional grounding function of 50% or 100% by internal type .

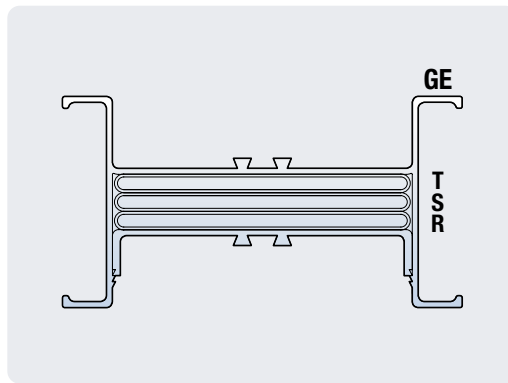

[3W+GE]

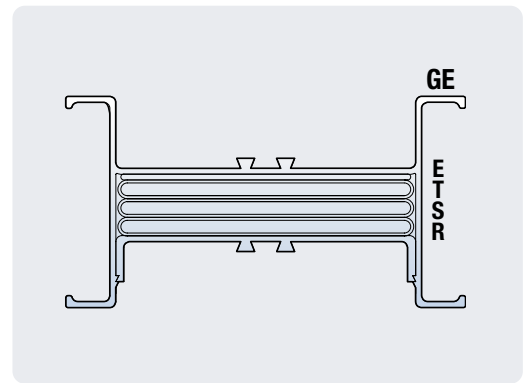

[3W+50%+GE]

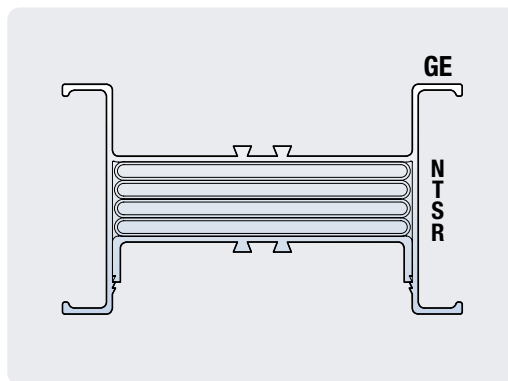

[4W+GE]

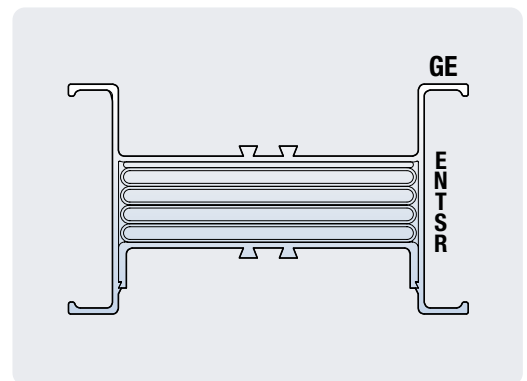

[4W+50%+GE]

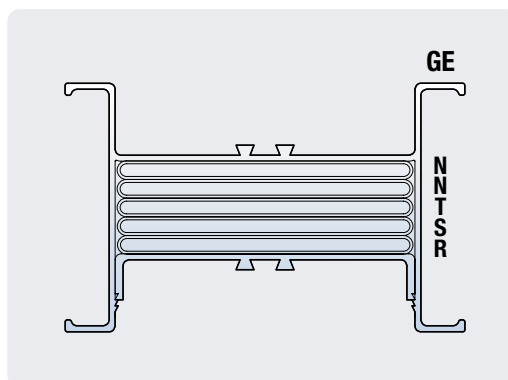

[4W(N=200%)+GE]

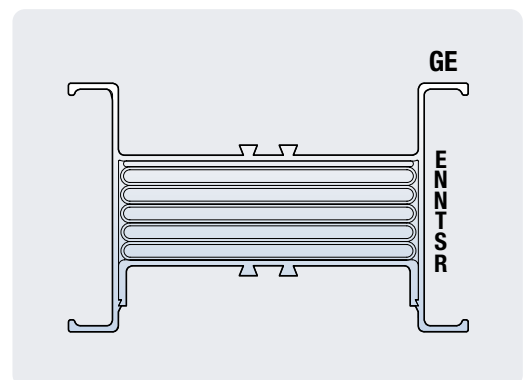

[4W(N=200%)+50%+GE]

# Susol Busways Components

*Susol*

Susol Busways offer various jointing components to meet any equipments and structures.



Feeder



Feeder with Plug-in Hole



Reducer



H-Elbow



V-Elbow



V-Tee Elbow



H-Offset Elbow



V-Offset Elbow



Combination Elbow

# Susol Busways Standard Components

Susol

## Feeder

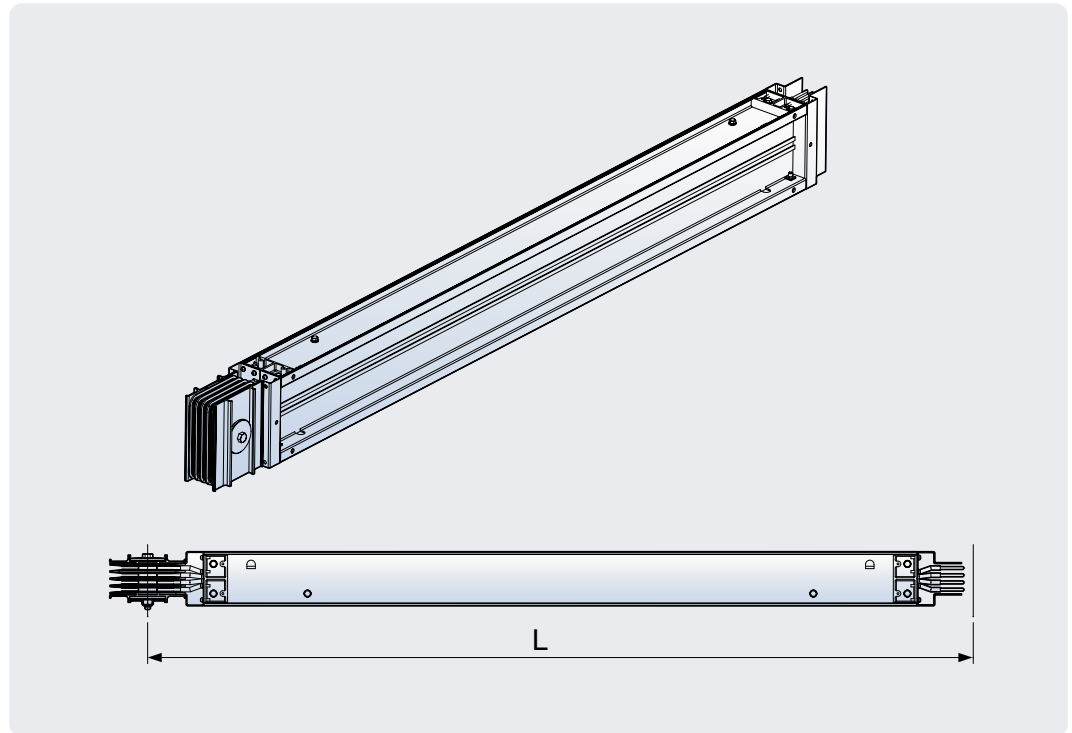

## Plug-in Feeder

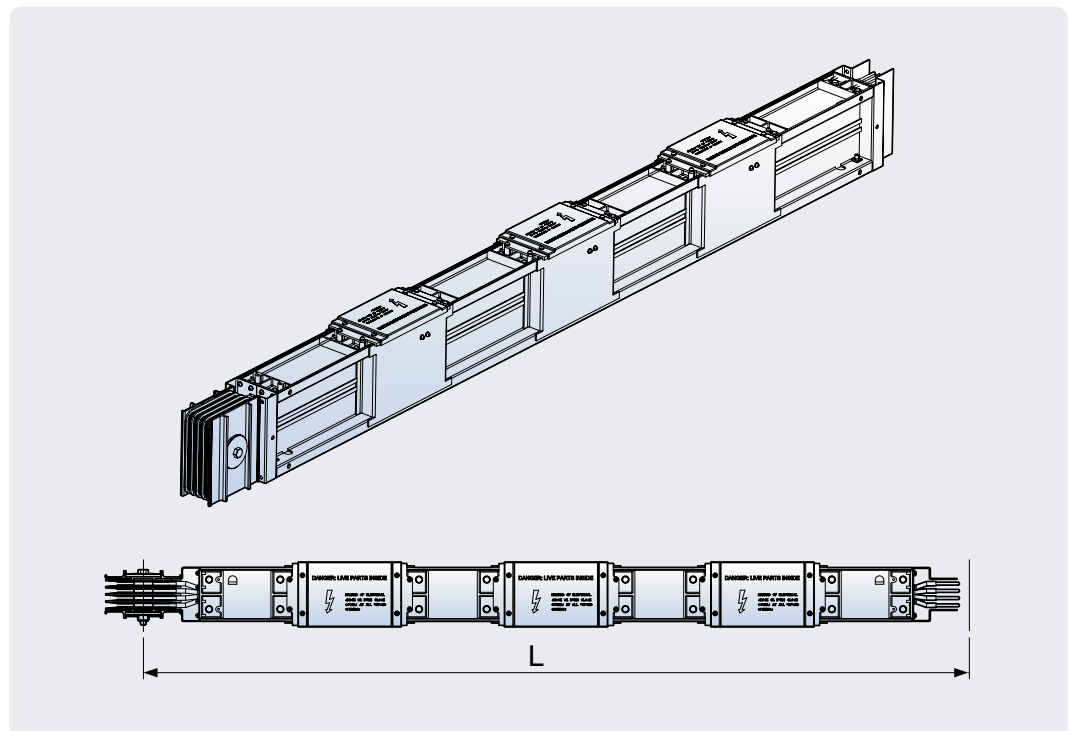

# Susol Busways Standard Components

Susol

## Elbow

### Horizontal Elbow

Conductor	Current(A)	Dimensions(mm)	
		L1	L2
Al	Total	500	
Cu			

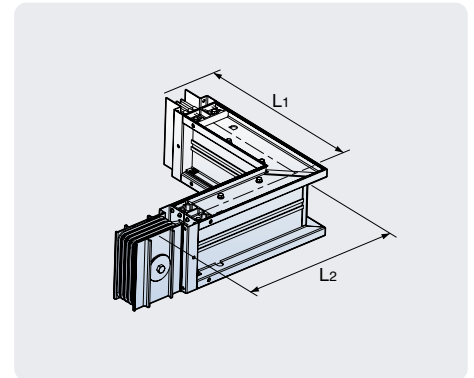

### Vertical Elbow

Conductor	Current(A)	Dimensions(mm)	
		L1	L2
Al	630~1250	400	
	1600~2500	500	
	3200~4000	600	
	5000~6000	700	
Cu	630~2000	400	
	2500~4000	500	
	5000~6000	600	
	7500	700	

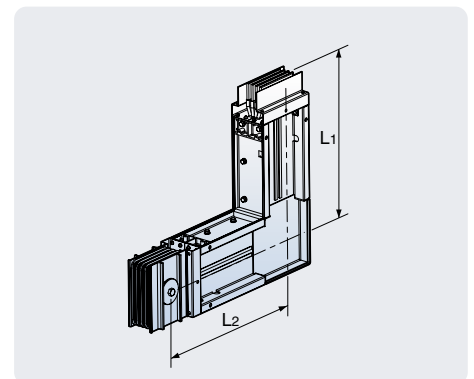

### Vertical Tee Elbow

Conductor	Current(A)	Dimensions(mm)		
		L1	L2	L3
Al	630~1250	400		
	1600~2500	500		
	3200~4000	600		
	5000~6000	700		
Cu	630~2000	400		
	2500~4000	500		
	5000~6000	600		
	7500	700		

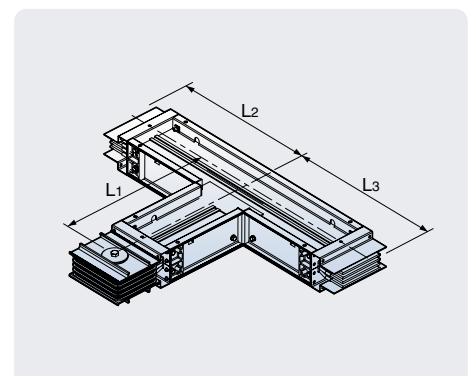



### Horizontal Offset Elbow

Conductor	Current(A)	Dimensions(mm)	
		L1	L2
Al	Total	500	
Cu			

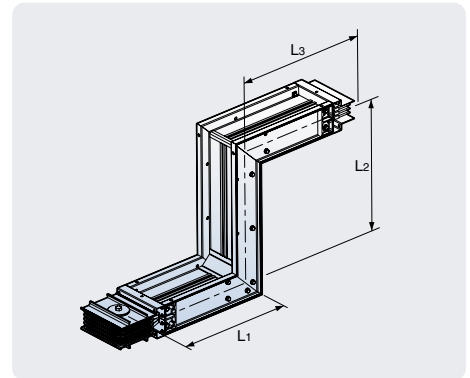

### Vertical Offset Elbow

Conductor	Current(A)	Dimensions(mm)		
		L1	L2	L3
Al	630~1250	400		
	1600~2500	500		
	3200~4000	600		
	5000~6000	700		
Cu	630~2000	400		
	2500~4000	500		
	5000~6000	600		
	7500	700		

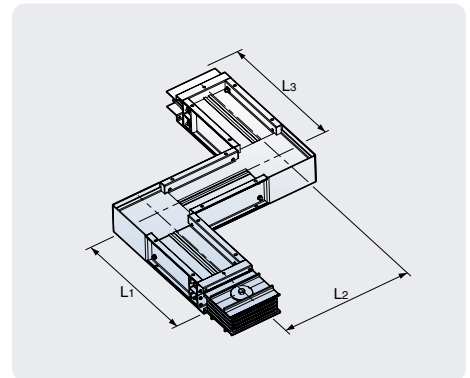

### Combination Elbow

Conductor	Current(A)	Dimensions(mm)		
		L1	L2	L3
Al	630~1250	400		
	1600~2500	500		
	3200~4000	600		
	5000~6000	700		
Cu	630~2000	400		
	2500~4000	500		
	5000~6000	600		
	7500	700		

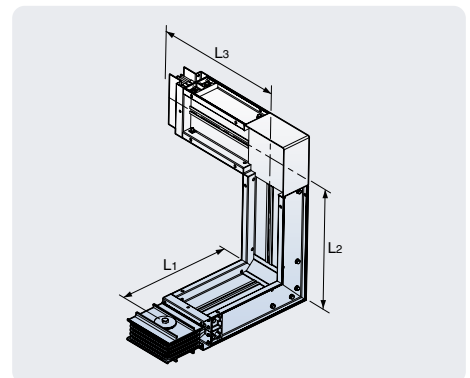

# Susol Busways Standard Components

Susol

## Reducer

Conductor	Current(A)	Dimensions(mm)		
		L1	L2	L3
Al	630~2000	500	500	1000
	2500~4000	500	600	1100
	5000~6000	500	750	1250
Cu	630~2500	500	500	1000
	3200~5000	500	600	1100
	6000~7500	500	750 </td <td>1250</td>	1250

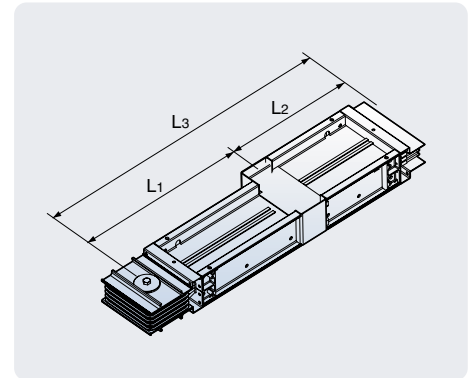

## Flange End

### 630~2500A : 1 Stack

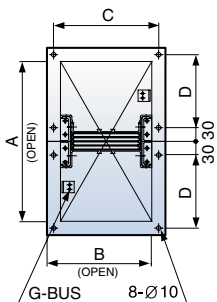

No.	Rated current(A)		Note) Fig.	Dimensions(mm)										
	Al	Cu		A(3W)	A(4W)	A(5W)	B	C	D(3W)	D(4W)	D(5W)	F	G	G-Bus
1	630	630, 800	Fig.1	250	350	450	96	126	110	160	210	41	-	3t × 25
2	-	1000					112	142				57	-	
3	800	-					117	147				62	-	
4	-	1250	128				158	73				40		
5	1000	-	141				171	86				40		
6	1250	1600	163				193	108				50		
7	-	2000	200				230	145				50		
8	1600	-	219				249	164				40	6t × 25	
9	-	2500	250				280	195				50		
10	2000	-	265				295	210				50		

Note : See the detail of terminal busbar

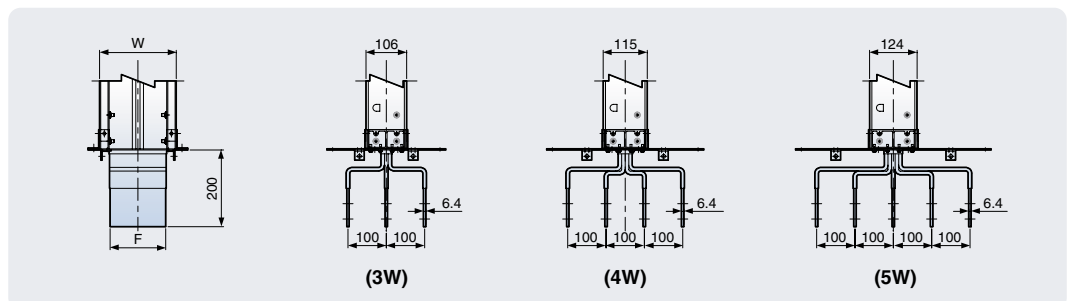

### 2500~5000A : 2 Stack

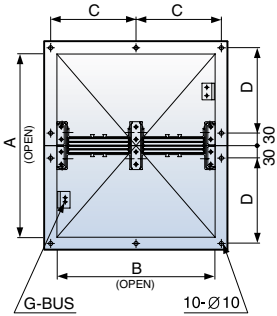

No.	Rated current(A)		Note) Fig.	Dimensions(mm)										
	Al	Cu		A(3W)	A(4W)	A(5W)	B	C	D(3W)	D(4W)	D(5W)	F	G	G-Bus
1	-	3200	Fig. 2	310	440	570	306	168	140	205	270	108	50	6t×40
2	2500	3600	Fig. 3				342	186				126	40	
3	-	4000	Fig. 4				380	205				145	50	
4	3200	-	Fig. 4				418	224				164	40	
5	3600	-	Fig. 4				458	244				184	45	
6	-	5000	Fig. 4				480	255				195	50	
7	4000	-	Fig. 4				510	270				210	50	

Note : See the detail of terminal busbar

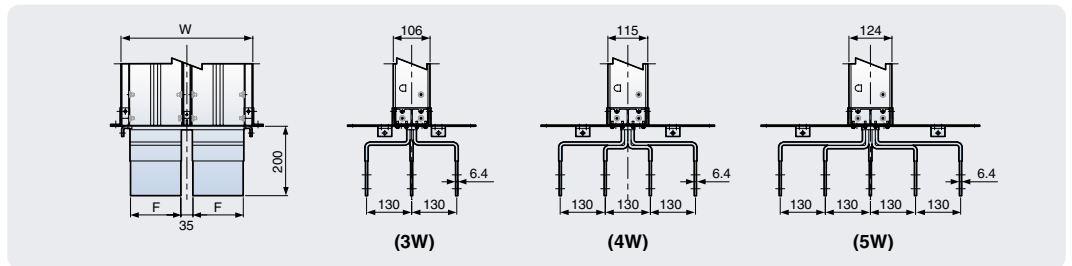

### 5000~7500A : 3 Stack

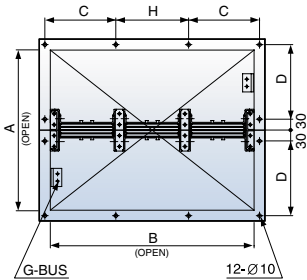

No.	Rated current(A)		Note) Fig.	Dimensions(mm)											
	Al	Cu		A(3W)	A(4W)	A(5W)	B	C	D(3W)	D(4W)	D(5W)	F	G	H	G-Bus
1	-	6000	Fig. 3	310	440	570	560	195	140	205	270	145	50	200	6t×50
2	5000	-	Fig. 4				677	234				184	45	239	
3	-	7500	Fig. 4				710	245				195	50	250	
4	6000	-	Fig. 4				755	260				210	50	265	

Note : See the detail of terminal busbar

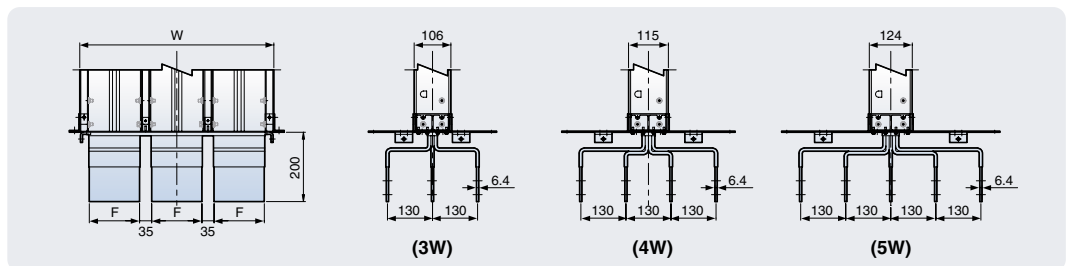

### Detail of terminal busbar

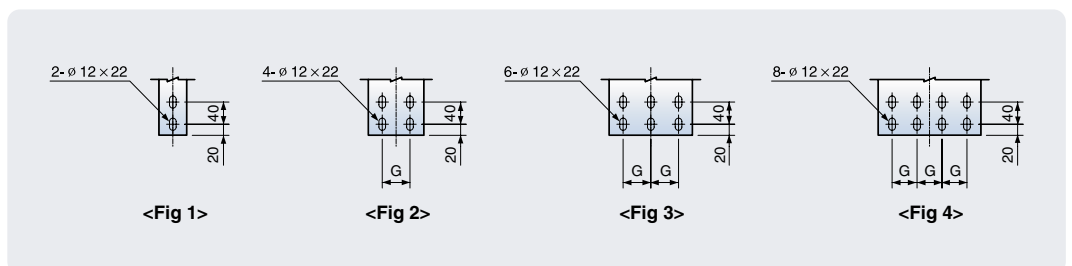

# Susol Busways Standard Components

Susol

## Flange

### Floor Type

No.	Rated current(A)		Dimensions(mm)
	Al	Cu	A
1	630	630, 800	116
2	-	1000	132
3	800	-	137
4	-	1250	148
5	1000	-	161
6	1250	1600	183
7	-	2000	220
8	1600	-	239
9	-	2500	270
10	2000	-	285
11	-	3200	326
12	2500	3600	362
13	-	4000	400
14	3200	-	438
15	3600	-	478
16	-	5000	500
17	4000	-	530
18	-	6000	580
19	5000	-	697
20	-	7500	730
21	6000	-	775

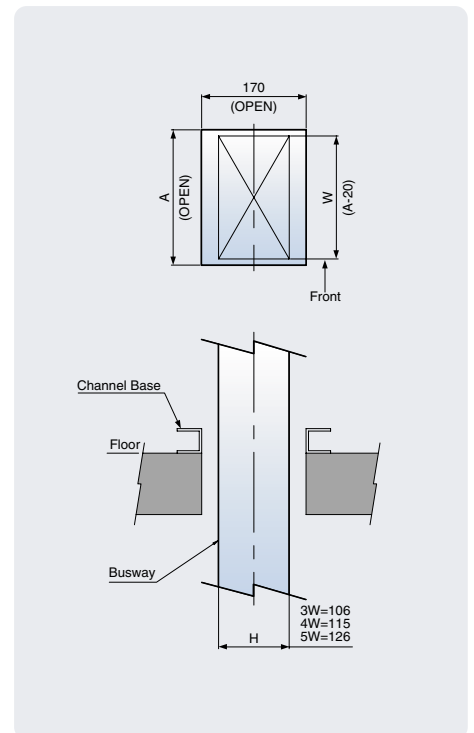

### Wall Type

No.	Rated current(A)		Dimensions(mm)
	Al	Cu	A
1	630	630, 800	156
2	-	1000	172
3	800	-	177
4	-	1250	188
5	1000	-	201
6	1250	1600	223
7	-	2000	260
8	1600	-	279
9	-	2500	320
10	2000	-	325
11	-	3200	366
12	2500	3600	402
13	-	4000	440
14	3200	-	478
15	3600	-	518
16	-	5000	540
17	4000	-	570
18	-	6000	620
19	5000	-	737
20	-	7500	770
21	6000	-	815

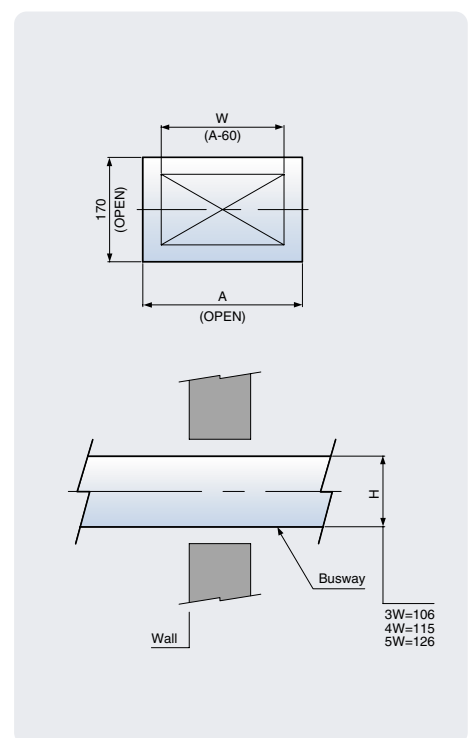

## Joint Detail

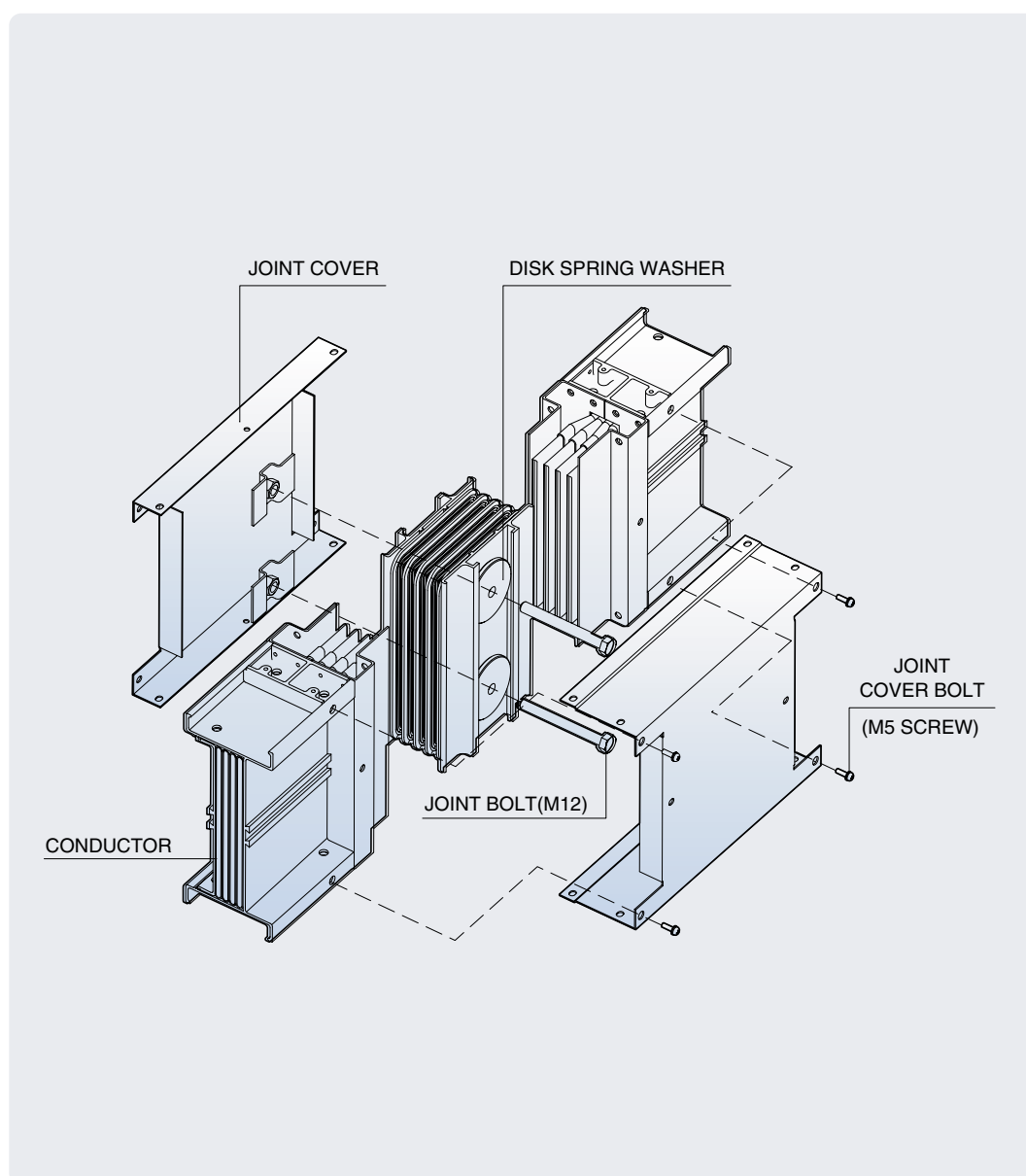

# Susol Busways Electrical Characteristics

Susol

## Short-time current capacity and impedance

### Aluminum Conductor

Conductor	Stack	Current(A)	Short-time current capacity(kA/1sec)	Impedance Data (X10 <sup>-5</sup> Ω/m)		
				R	X	Z
Al	1	630	20	14.06	3.83	14.57
		800	35	9.19	3.28	9.76
		1000	50	6.59	2.29	6.97
		1250	60	5.23	2.10	5.63
		1600	95	3.43	1.57	3.77
		2000	121	2.67	0.95	2.84
	2	2500	140	2.24	0.85	2.39
		3200	170	1.71	0.79	1.89
		3600	180	1.53	0.75	1.70
		4000	200	1.34	0.46	1.41
	3	5000	200	1.02	0.35	1.08
		6000	200	0.89	0.31	0.94

### Copper Conductor

Conductor	Stack	Current(A)	Short-time current capacity(kA/1sec)	Impedance Data (X10 <sup>-5</sup> Ω/m)		
				R	X	Z
Cu	1	630	35	8.00	3.93	8.91
		800	35	8.00	3.93	8.91
		1000	50	5.70	3.11	6.49
		1250	65	4.42	2.56	5.11
		1600	95	2.97	1.64	3.39
		2000	135	2.21	1.25	2.54
	2	2500	150	1.64	0.89	1.86
		3200	190	1.49	1.02	1.80
		3600	200	1.27	0.88	1.55
		4000	220	1.10	0.75	1.33
	3	5000	220	0.82	0.56	0.99
		6000	220	0.74	0.50	0.89
		7500	220	0.55	0.37	0.66

## Voltage drop

### Aluminum Conductor

(Unit : Volt/100m)

Conductor	Stack	Current(A)	Busbar Size (mm)		Power Factor(%)					
			Thickness	Wide	0.5	0.6	0.7	0.8	0.9	1.0
Al	1	630	6.40	41	11.29	12.55	13.73	14.78	15.63	15.34
		800		62	10.30	11.28	12.16	12.92	13.44	12.74
		1000		86	9.14	10.02	10.82	11.50	11.99	11.41
		1250		108	9.60	10.43	11.17	11.78	12.17	11.32
		1600		164	8.52	9.18	9.76	10.21	10.44	9.50
		2000		210	7.48	8.19	8.83	9.38	9.76	9.25
	2	2500		126	8.03	8.75	9.41	9.95	10.32	9.68
		3200		164	8.54	9.20	9.78	10.23	10.46	9.50
		3600		184	8.81	9.45	10.00	10.42	10.60	9.51
		4000		210	7.39	8.10	8.75	9.32	9.72	9.25
	3	5000		184	7.03	7.71	8.33	8.87	9.25	8.81
		6000		210	7.42	8.13	8.78	9.34	9.73	9.25

### Copper Conductor

(Unit : Volt/100m)

Conductor	Stack	Current(A)	Busbar Size (mm)		Power Factor(%)					
			Thickness	Wide	0.5	0.6	0.7	0.8	0.9	1.0
Cu	1	630	6.40	41	8.08	8.67	9.17	9.55	9.72	8.73
		800		41	10.26	11.00	11.64	12.13	12.35	11.08
		1000		57	9.60	10.23	10.75	11.13	11.23	9.87
		1250		73	9.59	10.18	10.66	10.99	11.04	9.58
		1600		108	8.05	8.58	9.01	9.32	9.39	8.24
		2000		145	7.57	8.05	8.44	8.71	8.77	7.64
	2	2500		195	6.88	7.34	7.71	7.98	8.06	7.09
		3200		108	9.01	9.46	9.80	9.98	9.88	8.24
		3600		126	8.72	9.15	9.47	9.63	9.53	7.93
		4000		145	8.32	8.74	9.06	9.23	9.14	7.64
	3	5000		195	7.74	8.13	8.42	8.58	8.49	7.09
		6000		145	8.32	8.74	9.06	9.23	9.14	7.64
		7500		195	7.71	8.10	8.39	8.55	8.47	7.09